

A real Pizzeria
in just 61cm...

Thanks to
2 cooking chambers
It fits all the needs



Cooking up
to **400°C**
for a perfect
Italian pizza

Refractory Stone
like in a real wood oven



Technical information

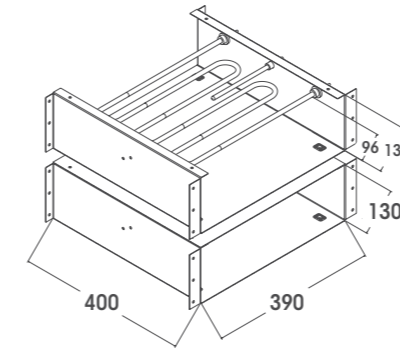
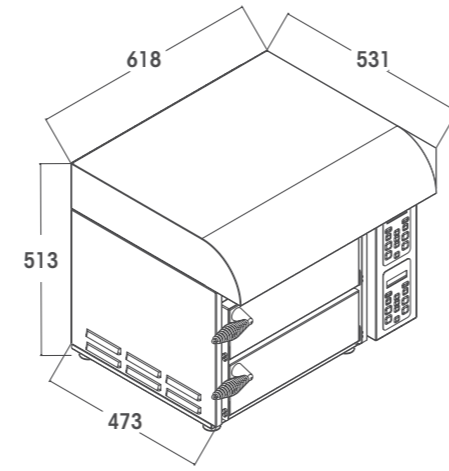

cooking chamber dimensions

ELECTRIC MULTIFUNCTION OVEN WITH TWO SEPARATE COOKING CHAMBERS

Size (H x W x D mm)	513 x 618 x 531
Colour / material	stainless steel (AISI 430)
Voltage	230 V
Frequency	50 Hz
Working temperature	50-450 °C (400°C for cooking pizza)
Max temperature	450 °C
Heating elements	1 per chamber - 1300 W each
Total electrical power	2600 W
Cavity (material, embossed or flat)	stainless steel + top-grade refractory stone, flat
Chambers' dimensions (H x W x D mm)	190 x 390 x 400
Net capacity	60 liters (30 liters per chamber)
Control type / User interface	Electronic easy-touch - 2 independent controls (1 per chamber)
Cooling fan system	2 cooling fans on rear side
Power cord supply	160 mm
Plug	standard European Shuko
Door Type	stainless steel door with cold handle
User Manual	IT - GB
SPECIAL FUNCTIONS	
4 programmable cooking cycles (time and temperature)	
Extractor hood with activate carbon filter	
ACCESSORIES	
Professional Pizza-shovel	1 (included)
Wire grid for "bruschette", sandwiches and toasts	optional
Special pan for cooking "spiedini" (skewer)	optional
LOGISTICS DATA	
Packaging dimensions (H x W x D mm)	560 x 780 x 590
Gross weight / Net weight	45 / 42 Kg
Loading quantity per euro-pallet (1200 x 800 mm)	6 units

the manufactured reserves the right to change the features of the product



www.FORNOCHEF.com

info@fornochef.com

Gemino s.r.l. - Via Circonvallazione, 9 - 28060 Comignago (No)

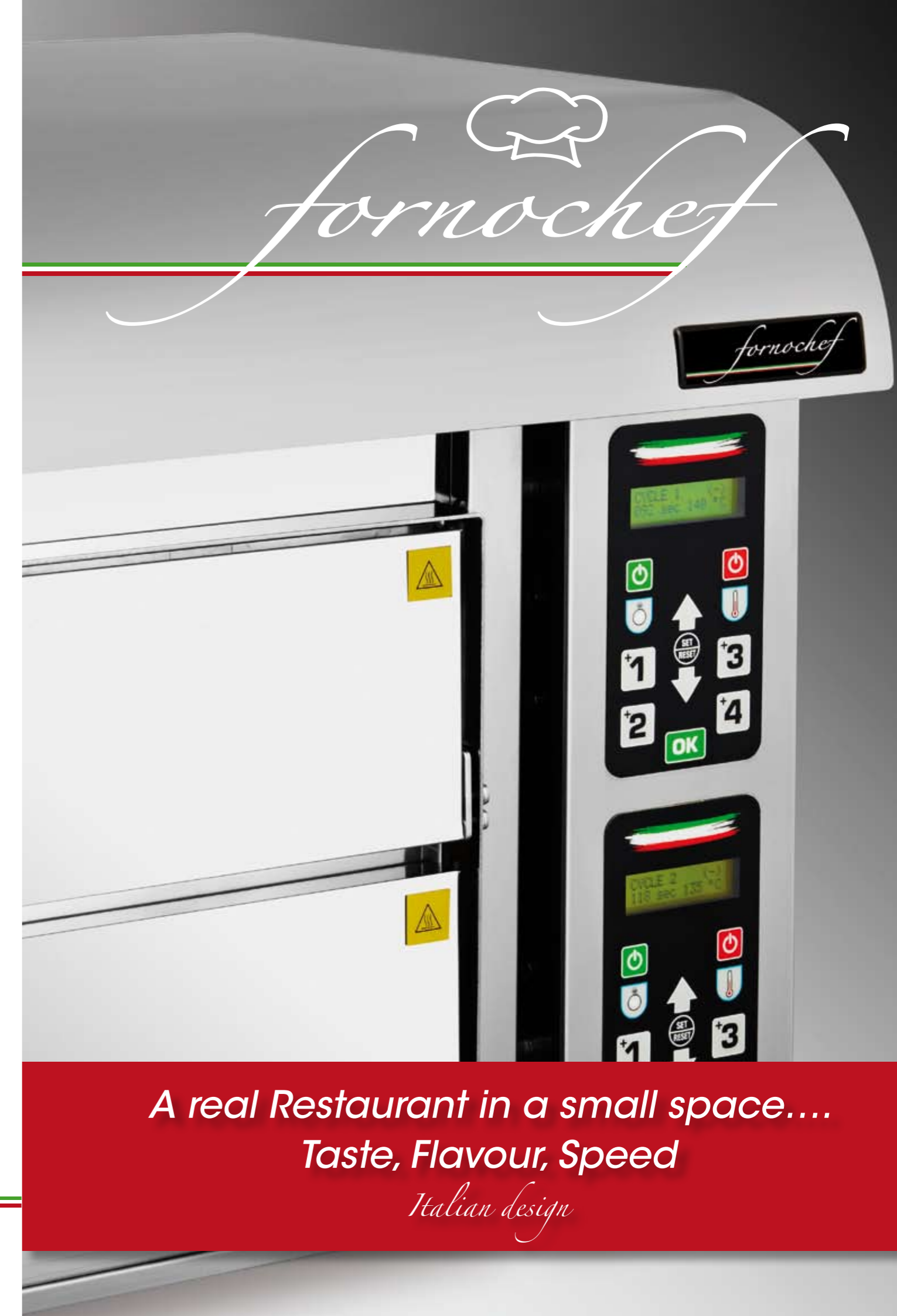

A real Restaurant in a small space....

Taste, Flavour, Speed

Italian design

Why choose it...

A single investment for endless delicious meals.

It is the ideal solution for structures that need an elegant DESIGN oven with professional performances for different cooking needs : pizza, bakery products, ready meals, pastry, appetizers.

Perfect for Pizzeria, Pubs, Fast-food vans.

fornocheff



- Quick and easy installation
- Also suitable for fast-food vans
- 2 independent cooking chambers (up to 4 different programs)
- Temperature setting from 50°C to 450°C by means of a thermostat and digital display
- Acoustic alarm at the end of the cooking programme
- Thermo-insulated "cold handles"
- Extractor hood with active carbon
- Active carbon filter at rear



www.FORNOCHEF.com



Active carbon filter



Design "cold handle"



Design pizza shovel handle



Ergonomic pizza shovel



Design hood extractor



Adjustable feet

The refractory stone guarantees the same fragrance as a wood oven, it absorbs the moisture of the pizza dough, the pizza will be crispy and it will not stick to the stone.

It cooks in 120 seconds...

It exalts the **Taste** and you save time, space and electricity.

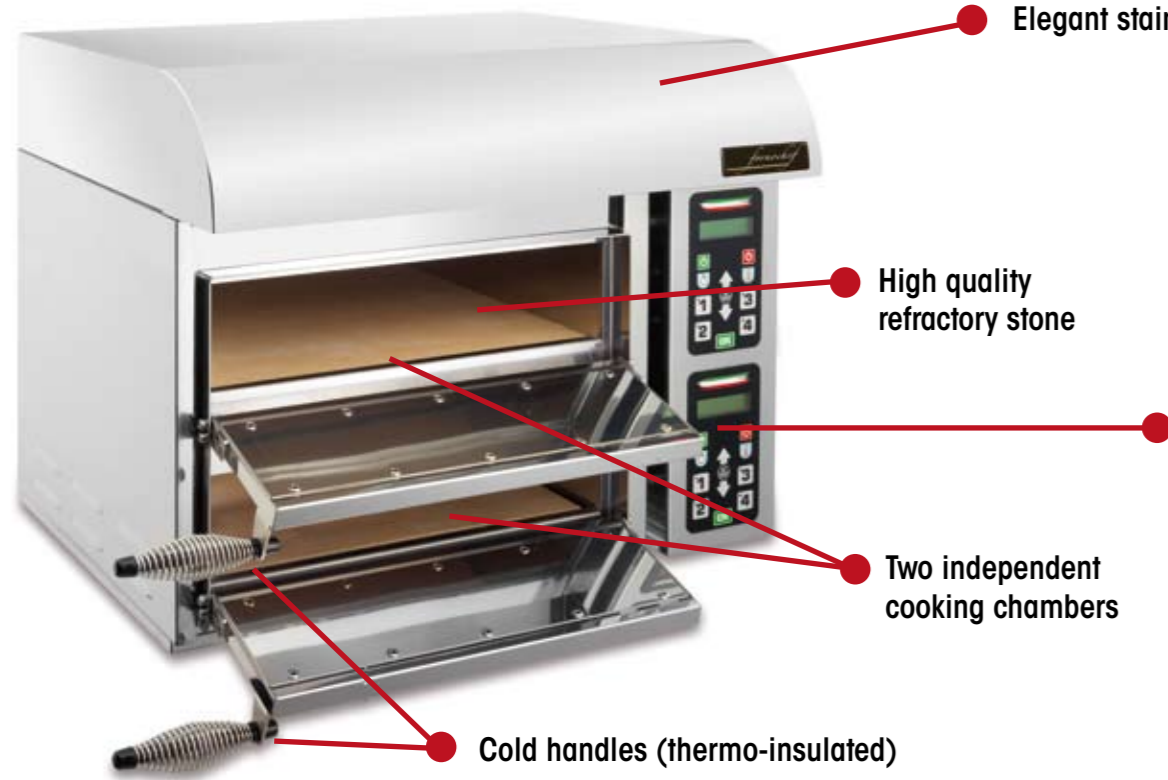

Elegant stainless steel design

High quality refractory stone

Two independent cooking chambers

Cold handles (thermo-insulated)



Control panel with digital display

In just 61cm...

you can turn your premises into a Pizzeria...and not only !

Traditional Pizza

Rectangular Pizza to sell in slices
Take away pizza and much more...



Piadine and Sandwiches...

focacce, sfogliatine, bruschette.



French fries...

potato croquettes, Ascolane olives, ready meals...

Chicken...

Chicken drumsticks and wings, speedy chicken.



fornocheff

Fish and meat on a skewer...

sausages, hamburgers, hot-dogs.



Tortillas...

Cakes and pies...

vegetable pies and anything else that needs cooking.

